

PRIMARY LEAVING EXAMINATION

2019

MATHEMATICS

Time Allowed: 2 hours 30 minutes

Index No.

| Random No. | Personal No. |
|------------|--------------|
| | |

Candidate's Name:

Candidate's Signature:

School Random No.

District ID:

Read the following instructions carefully:

1. Do not write your **school** or **district name** anywhere on this paper.
2. This paper has **two** sections: **A** and **B**. Section **A** has **20** questions and section **B** has **12** questions. The paper has **16 printed pages**.
3. Answer **all** questions. **All** the working for both sections **A** and **B** must be shown in the spaces provided.
4. **All** working **must** be done using a **blue** or **black** ball point pen or ink. Any work done in pencil other than graphs and diagrams will **not** be marked.
5. **No calculators** are allowed in the examination room.
6. Unnecessary **changes** in your work and handwriting that cannot easily be read may lead to **loss of marks**.
7. Do not fill anything in the table indicated: **"For Examiners' use only"** and boxes inside the question paper.

| FOR EXAMINERS' USE ONLY | | |
|-------------------------|-------|-----------|
| Qn. No. | MARKS | EXR'S NO. |
| 1 - 5 | | |
| 6 - 10 | | |
| 11 - 15 | | |
| 16 - 20 | | |
| 21 - 22 | | |
| 23 - 24 | | |
| 25 - 26 | | |
| 27 - 28 | | |
| 29 - 30 | | |
| 31 - 32 | | |
| TOTAL | | |

SECTION A: 40 MARKS

Answer **all** the questions in this section

Questions **1** to **20** carry two marks each

1. Work out:

$$\begin{array}{r} 534 \\ -123 \\ \hline \end{array}$$

2. Write XCVII in Hindu Arabic numerals.

3. Simplify: $3p + p - 2p$

4. In the Venn diagram below, shade the region $(S \cup T)'$

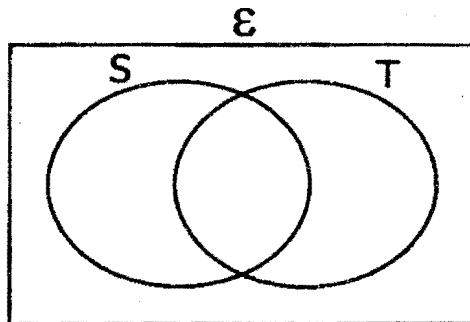





5. Round off 53.86 to the nearest tenth.



6. Using a pair of compasses, a pencil and a ruler only, construct a perpendicular from point C onto the line segment AB below.



7. Change 250 grammes into kilogrammes.

8. Given that  represents 26 girls in a class and  represents 20 boys in the class, find the total number of pupils represented by   .

9. Solve: $3 + m = 2(\text{finite } 5)$

10. In the diagram below, find the value of b in degrees.

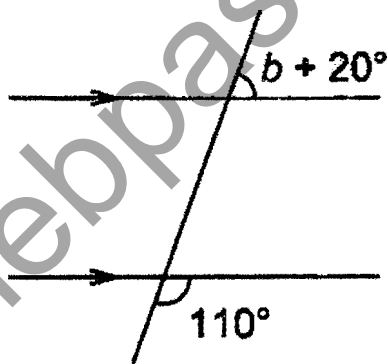

11. Find the next number in the sequence:

58, 33, 17, 8, _____

12. Calculate the speed of a motorist who covered a distance of 210 kilometres in $2\frac{1}{2}$ hours.

13. Change 8_{ten} to binary system.

14. Find the smallest number that can be divided by 8 or 12 and leaves 5 as the remainder.

15. A teacher deposited sh 72,000 in a bank. After one year, the teacher earned a simple interest of sh 3,600. Calculate the simple interest rate of the bank.

16. Study the coordinate graph below and use it to answer the questions that follow:

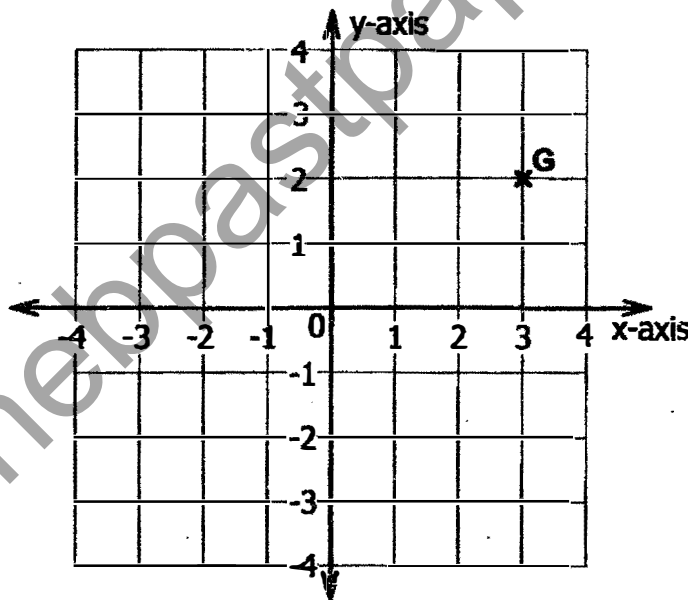

- (a) Write the coordinates of point **G**.
- (b) Plot the point **H**(-3,0) on the coordinate graph.

17. A train left station K at 11 38 hours and reached station M at 14 27 hours. How long did the train take to travel from K to M ?
18. Find the solution set for $k + 2 < 6$.
19. A shopkeeper bought 19 plates at sh 34,200. At what price must the shopkeeper sell each plate in order to raise a profit of sh 3,800?
20. Mawa built a circular hut of circumference 66 metres using poles. The poles were fixed at intervals of 1.5 metres. Calculate the number of poles he used.

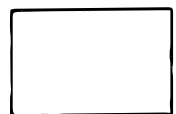

SECTION B: 60 MARKS

Answer **all** questions in this section

Marks for each question are indicated in brackets

21. The diagrams below represent subtraction of two numbers on abacus. Study the diagrams and use them to answer the questions that follow:

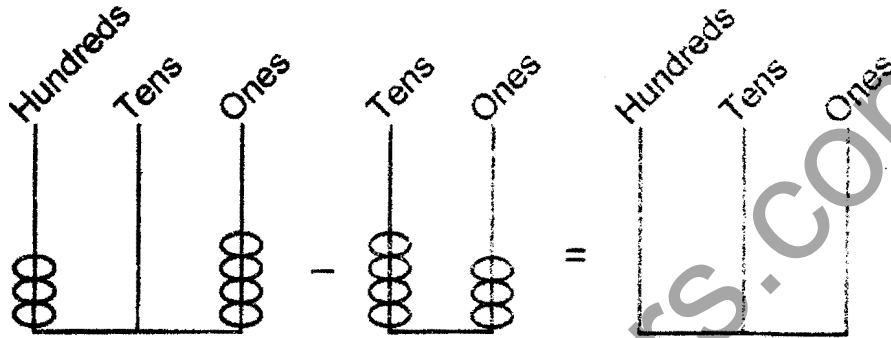

- (a) Write down the numbers represented in the subtraction. (02 marks)
- (b) Work out the subtraction and represent your answer on the third abacus. (03 marks)

22. A class of 68 pupils was served matooke (M) and rice (R). 30 pupils ate matooke and $2h$ ate rice. 7 pupils ate both matooke and rice while 9 pupils did not eat either of the foods.

- (a) Use the given information to complete the Venn diagram below. (02 marks)

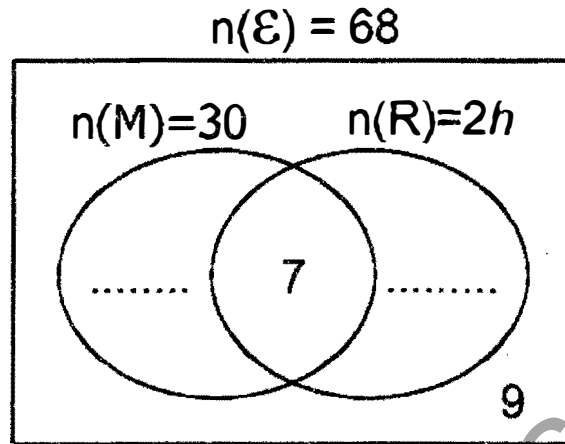

- (b) How many pupils ate rice only? (03 marks)

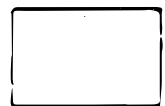

23. (a) Work out: $\frac{2.4 \times 0.5}{0.12}$ (03 marks)

(b) Simplify: $0.37 - 1.03 + 2.6$

(02 marks)

24. In the figure below, PQ is parallel to RS and AB is perpendicular to AR . Study the figure and answer the question that follows.

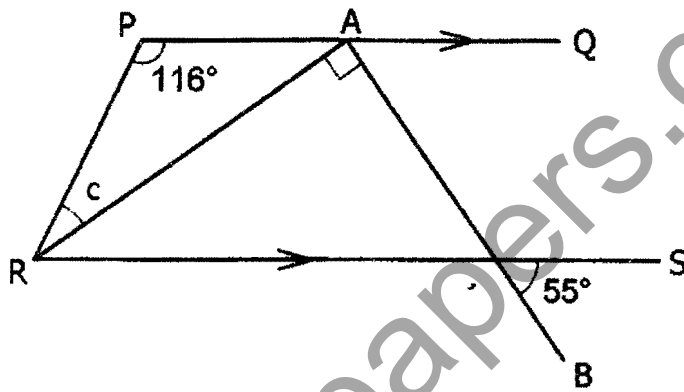

Find the size of angle c .

(04 marks)

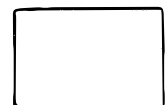

25. The diagram below represents a container which a shopkeeper uses to sell cooking oil.

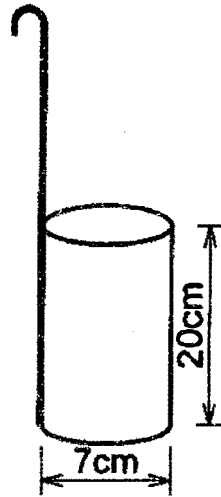

On a certain day, the shopkeeper sold 15.4 litres of cooking oil. How many such containers of cooking oil were sold that day? (Use $\pi = \frac{22}{7}$).
(05 marks)

26. Kizza went to a market with sh. 30,000. She bought the items shown in the table below. After paying for all the items, she remained with sh. 9,250.

Complete the table.

(06 marks)

| Item | Unit cost | Total cost |
|--------------------------|--------------------|------------|
| 2 kg of sugar | sh 4,000 per kg | sh |
| 3 loaves of bread | sh per loaf | sh |
| litres of milk | sh 1,500 per litre | sh 2,250 |
| Total Expenditure | | sh |



27. A bus that left town *A* at 11:30 a.m. moving at a speed of 60 km/h reached town *B* at 1:30 p.m. The bus stayed at town *B* for 40 minutes. It then continued to town *C* and covered a distance of 96 Kilometres at a speed of 64 km/h.

- (a) Calculate the total distance covered by the bus from town *A* to town *C*.

(03 marks)

(b) At what time did the bus reach town C ?

(03 marks)

28. The table below shows the marks obtained by some pupils in a test. Use the information to answer the question that follows.

| | | | | |
|------------------|----|-----|----|----|
| Marks | 40 | m | 60 | 70 |
| Number of pupils | 2 | 6 | 3 | 3 |

If the mean mark of the pupils was 55, find the value of m . (04 marks)



29. The number of goats, cows and sheep on a certain farm are in the ratio of 4:3:5 respectively. There are 40 more sheep than goats on the farm. Find the number of each type of animal on the farm.

(05 marks)

30. In the parallelogram $ABCD$ below, lines DX and DY are perpendiculars to AB and BC respectively. Line $AB = 16$ cm, $BC = 12$ cm and $DX = 6$ cm.

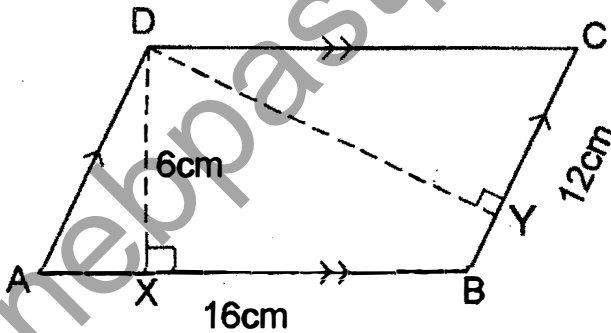

- (a) Calculate the area of the parallelogram.

(02 marks)

(b) Find the length DY .

(03 marks)



31. In a market, the cost of a pawpaw is sh 800 more than the cost of a mango. A mango costs two thirds of the cost of a pineapple. The total cost of the three fruits is sh 4,300. Calculate the cost of a pineapple.

(04 marks)

unebpastpapers.com

32. A boatman sailed from island P on a bearing of 300° to island Q for a distance of 56 km. The boatman then left island Q and sailed on a bearing of 230° to island R for a distance of 40 km.

(a) Using a scale of 1 centimetre to represent 8 kilometres, draw an accurate diagram to show the route of the boatman.

(05 marks)

unebpastpapers.com



(b) Find the bearing of island R from island P .

(01 mark)

